

DERON

COMBINATION DUSTER

Blanket Dust or Trickle Dust



THE DERON LPD5 COMBINATION DUSTER

is designed to blanket dust or trickle dust. The LPD5 is equipped with a 5 HP Permissible Motor direct coupled to the blower, eliminating the need for V-belts. The LPD5 is approved by MSHA and PA for underground operation. The LPD5's 5 HP motor (460 or 575 VAC) and positive displacement blower produce total rockdust aeration. The Deron LPD5 has a 650 lb. hopper with stainless steel baffles. Using a 1 1/2" diameter hose the 10 psi operating pressure allows the LPD5 to blanket dust up to 200 ft. and trickle dust up to 400 ft.

With its compact design and quick opening hatch, bag filling of the Deron LPD5 is an easy job. The Deron LPD5 Combination Duster adapts to your method of rockdusting. Models are available skid mounted as shown, or on three (3) solid rubber tires.

FEATURES:

- Total Rockdust Aeration
- Direct Drive (No V-belts)
- Quick Opening Hatch
- Adjustable Discharge Rate Pressurized (10 psi) Hopper w/Stainless Steel Baffles
- Removable Aeration Chamber
- MSHA Approval No. 2G-3446A-0
- PA Approval No. BFE-949-84

SPECIFICATIONS:

- 5 HP Motor/460 or 575 VAC
- Hopper Capacity 1,000 lbs.
- Blanket Dust-up to 200 ft. w/1-1/2" hose
- Trickle Dust-up to 400 ft. w/1-1/2" hose

DIMENSIONS:

- Skid Mounted - 82-3/4"L x 39-1/2"H x 36"W
- Wheel Mounted - 92-1/2"L x 35"H x 36"W

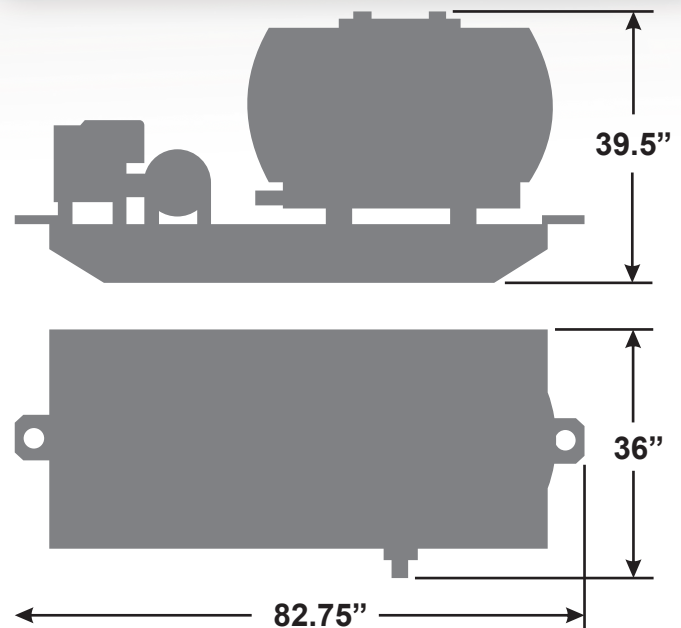

DERON

ELECTRIC TRICKLE DUSTER

#1 Choice for Trouble Free Trickle Dusting

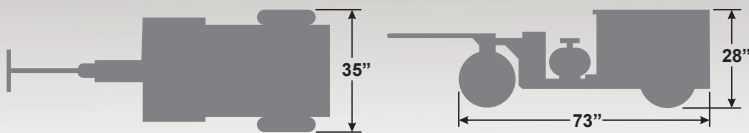

THE DERON ETD2 ELECTRIC TRICKLE DUSTER

is the mining industry's preferred machine for trouble-free trickle dusting. Approved by MSHA and PA, the Deron ETD2's 2 HP Permissible Motor direct coupled to a 3300 Series Blower eliminates any V-belt maintenance. The fully aerated rockdust chamber, the patented Venturi Pick-Up, plus the adjustable discharge rate, produces successful unattended trickle dusting.

A sliding hopper lid enables the operator to fill the 450 lb. hopper with quickness and ease. Built for excellence in performance, the Deron ETD2 Electric Trickle Duster is available as shown on three (3) solid rubber tires or skid mounted.



FEATURES:

- 2 HP Permissible Motor and Starter
- Direct Drive Chain Type Coupling Between Motor and Blower
- 450 lb. Hopper with Sliding Lid
- Removable Aeration Chamber
- Patented Venturi Pick-Up
- Adjustable Discharge Rate
- MSHA Approval No. 2G-3403A-O
- PA Approval No. BFE-888-83
- Three (3) Solid Rubber Tires



SPECIFICATIONS:

- Operates on 460 or 575 Volts, A/C, 60 Hz, 3 Phase
- Dimensions: 28" high x 35" wide x 73" long (wheel mounted) 27" high x 37" wide x 62" long (skid mounted)
- Discharge Rate: 1/2-5 lb. per minute thru 1-1/2" hose
- 5" Ground Clearance (Wheel Mounted)

DERON

HYDRAULIC ROCK DUSTER

Easily Transported.....Just a Drop in the Bucket

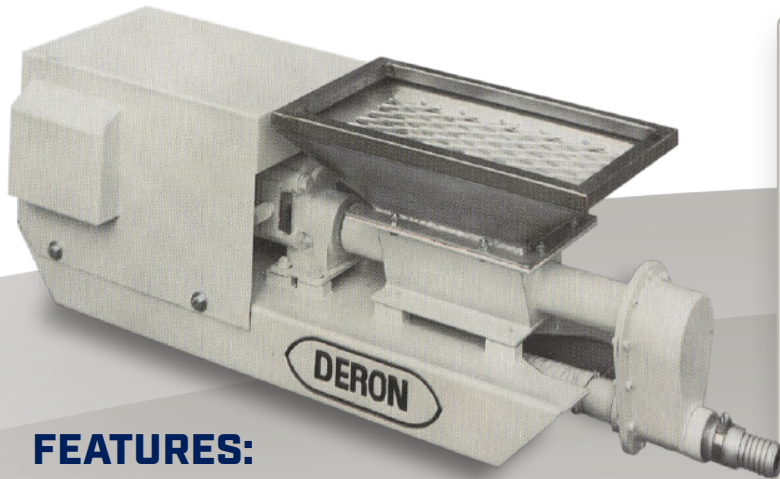

THE DERON RD55 HYDRAULIC ROCKDUSTER

can be used to effectively dust working sections in the mine and is designed to be transported in the bucket of a scoop car which permits dusting in less accessible areas of the mine. The RD55 uses a parallel shaft hydraulic motor, allowing the auger and blower to be direct coupled, thus eliminating V-belts and gear drives.

A stainless steel hopper with capacities of 50 lb., 100 lb., and 150 lb. permit the rockdust to slide freely to the auger. The Deron RD55, available in three (3) hydraulic motor sizes, is able to accommodate most underground mining equipment, and using a 2" hose, the RD55 has a maximum rockdusting capability of up to 100 lb. per minute (depending on hose length).

FEATURES:

- Direct Drive/Three (3) Motor Sizes Available
- Stainless Steel Hopper
- Direct Coupling Eliminates V-belts or Gear Drives
- Protective Cover for Blower
- Optional Mounting Methods

SPECIFICATIONS:

- Hydraulic Motor Sizes:
 - 9-15 GPM @ 1500 psi
 - 15-25 GPM @1500 psi
 - 25-35 GPM @1500 psi
- Hopper Capacities: 50 lb.-100 lb.-150 lb.
- Dusting Capacity: 100 lb./min up to 50 ft. w/2" hose

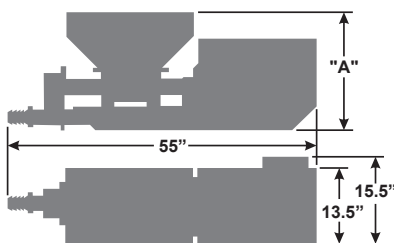

Model	Req'd GPM	Hopper Capacity	Dim. "A"
RDL55-300	9-15 GPM	50 LBS	16.5"
RDL55-400	15-25 GPM	50 LBS	16.5"
RDL55-500	25-35 GPM	50 LBS	16.5"
RD55-300	9-15 GPM	100 LBS	20.5"
RD55-400	15-25 GPM	100 LBS	20.5"
RD55-500	25-35 GPM	100 LBS	20.5"
RDH55-300	9-15 GPM	150 LBS	24.5"
RDH55-400	15-25 GPM	150 LBS	24.5"
RDH55-500	25-35 GPM	150 LBS	25.5"

DERON

SLINGER DUSTER

The Ultimate Design for One Man Rock Dusting



THE DERON SD2 SLINGER-DUSTER

is designed for ultimate rockdusting efficiency and performance. The unique design of this unit incorporates two (2) powerful direct drive hydraulic motors which provide power for the augers and dust fingers, while one (1) low speed, high torque hydraulic motor drives the agitators. Preset speed of the hydraulic motors provides the optimum discharge rate, while adjustable deflector plates allow the operator to easily control the discharge pattern of rockdust as required. Rugged design, heavy duty construction, skid mounted and open center frame are features of the Deron SD2 Slinger-Duster that enables easy loading in a scoop bucket. The rotating Z-shaped agitators add to total hopper clean out. The Deron SD2 Slinger-Duster reduces costs and increases rockdusting productivity with ease of transport, loading and performance. The SD2 has a standard capacity of 2400 lbs. (Larger capacities are available, see optional capacity chart.)

FEATURES:

- Skid Mounted (Trailer Models Available)
- Rotating Z-Shaped Agitators
- Direct Drive Auger and Flinger
- Open Center (To Fit Over Ejector Cylinder)
- Protective Top Screen
- Adjustable Dust Deflector Plates
- Protective Bumper

SPECIFICATIONS:

- 2400 lb. Capacity (Larger Capacities Available)
- Oil Requirement: Min. 15 GPM @ 1800 psi

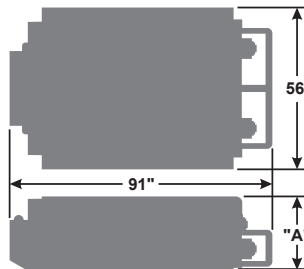

Optional Dust Capacity	Dim. "A"
2400 LBS	24"
3500 LBS	30"
5000 LBS	38"
6000 LBS	44"
7000 LBS	49"

DERON

STRAP DUSTER

Easy on, Easy off

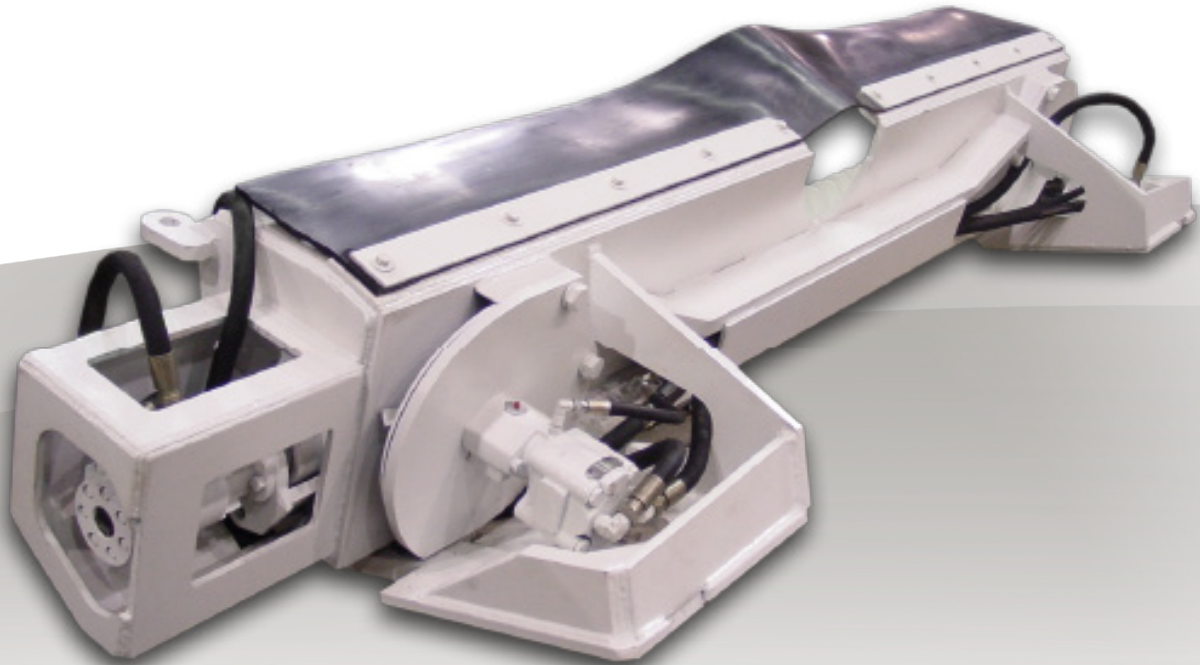

FEATURES:

- Custom built to fit any size bucket
- 18 Cubic Feet Per Min (20 gpm @ 1500 psi)
- Supplied Hydraulic Disconnects
- Designed for ultimate rockdusting efficiency and performance
- Two (2) powerful direct drive hydraulic motors which power dust flingers
- Rugged design, heavy duty construction, easy loading in a scoop bucket
- Reduces operating costs and increases rockdusting productivity with ease of transport, loading and performance



REQUIREMENTS:

- Min. 10 gpm
- Min. 1000 psi
- Customer to weld supplied binder stub to scoop bucket